

S-125-12SG
(SEE ENLARGED DETAIL BELOW.)

PAPER SIZE		DRAWING NUMBER	
B	SIZE	GD-S-125-12SG	
REV	REVISION DATE	ECO	
A	7-9-19	D9540	

- NOTES
- MATERIAL: 1.66" X 12 GA. STEEL TUBE
 - FINISH: HOT DIP GALVANIZE PER ASTM A-123
 - HARDWARE:
 - 3/8" X 1 1/4" CARR. BOLT WITH NUT, LOCKWASHER, AND 13/32" CLIP WASHER (GROUNDING PROVISION)
 - 1/2" U-BOLT WITH NUTS AND FLAT WASHERS
 - 1/2" X 96" WITH (4) NUTS (DOUBLE NUT EACH END) AND (4) FLAT WASHERS
 - APPROX. WEIGHT: 36#

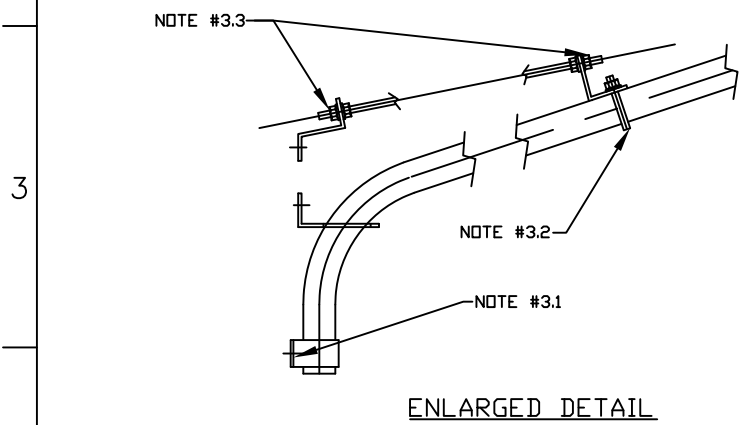

ENLARGED DETAIL

QTY.	DESCRIPTION
1	3/8" HEX NUT
1	3/8" LOCK WASHER
1	3/8" X 1-1/4" CARRIAGE BOLT
1	GALV. WELD
1	CLIP WASHER
6	1/2" HEX NUT
6	1/2" FLAT WASHER
1	1/2" U-BOLT
1	1/2" X 96" TIE ROD
1	GUYROD BRKT
1	GUY BRKT, POLE

TOLERANCES UNLESS SPECIFIED	
inch	
0.XX	± 0.5
0.XXX	-----
ANGLE	± 1°



DRAWN BY	ENGINEER	CHECKER	CATALOG #	SCALE	DESIGN DATE
JSS	JSS	-	S-125-12SG	NTS	12/13/01
DRAWING TITLE / DESCRIPTION					DRAWING NUMBER
1-1/4" X 12' MASTARM WITH SINGLE GUYROD					GD-S-125-12SG

This drawing contains confidential information that is the property of MacLean Power, L.L.C. ("MacLean"). Use of MacLean's confidential information without MacLean's express written consent is strictly prohibited and may expose you to legal liability. If you believe that you received this material in error, please destroy it or return it to "MacLean Power, L.L.C., 11411 Addison, Franklin Park, Illinois 60131, USA."