

8 7 6 5 4 3 2 1

D
C
B
A

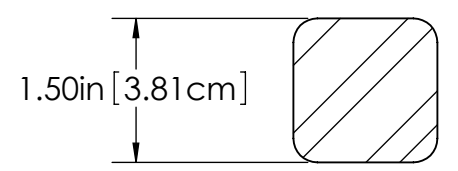

SECTION A-A
SCALE 1 : 2

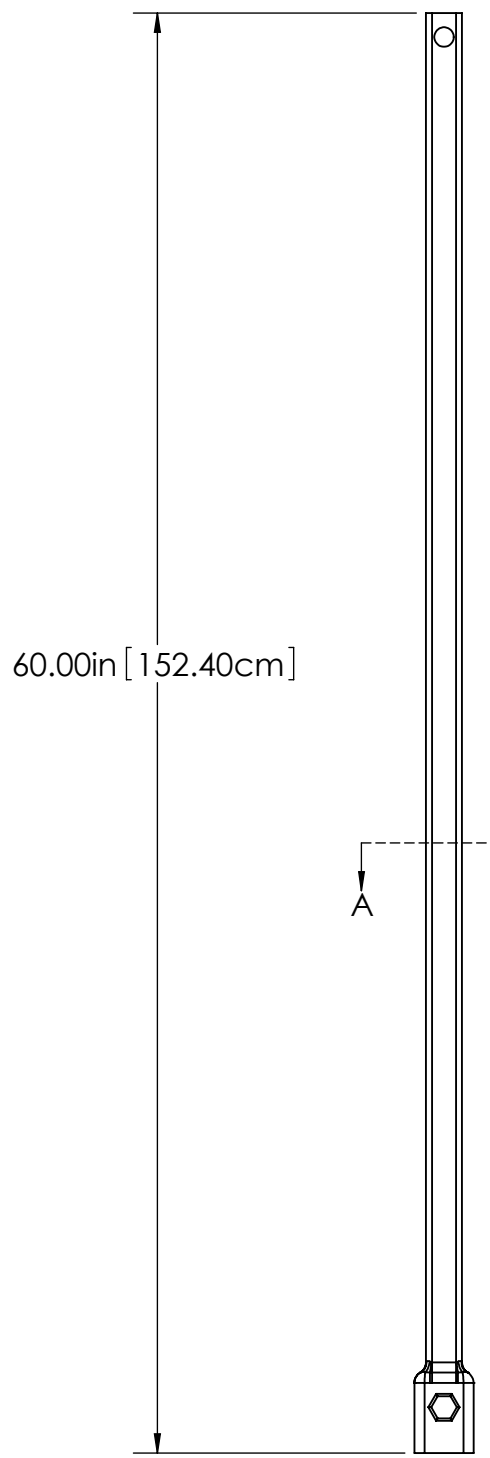
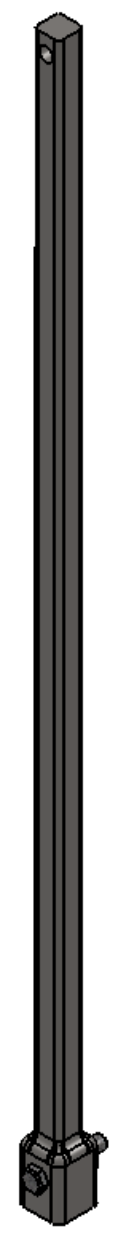

NOTES:

1. HOT DIP GALV. PER ASTM A123, AFTER FABRICATION.
2. TORQUE RATING - 5,500 FT-LB (7457 Nm)
3. 55,000 lbf [245,000 N] TENSILE RATING
4. COUPLING BOLTS: 3/4" DIAMETER X 3" LONG HEX HEAD PER ASTM A325 AND 3/4" HEX JAM NUTS PER ASTM A563.

This drawing contains confidential information that is the property of MacLean Power, L.L.C. ("MacLean"). Use of MacLean's confidential information without MacLean's express written consent is strictly prohibited and may expose you to legal liability. If you believe that you received this material in error, please destroy it or return it to "MacLean Power, L.L.C., 11411 Addison Street, Franklin Park, Illinois 60131, "USA."



DRAWING NUMBER:		D6620U
SHEET NAME:	SHEET1	1 OF 1
PRODUCT DESCRIPTION		
1-1/2" 5,500 ft/lb POWER SHAFT RCS EXTENSION		
DRAWN BY:	CRL	DATE: 3/13/12

8 7 6 5 4 3 2 1